



# SPS16000

16 mt lifting moment

- Longer boom ideal for wide working area
- Strong lifting performance due to proprietary technology
- Proportional control valve allows smooth controllability and high operating efficiency
- More transport capacity thanks to the optimized, lighter crane structure
- Manufactured with European quality processes to ensure safety and reliability

**5.2m**

Front stabilizer spread

**14.4m**

Max. lifting height

## Technical Specifications

Item	Unit	SPS16000
Max. Lifting Moment	mt	16
Max. Lifting Capacity	kg/m	7000/2.5
Max. Lifting Height	m	14.4
Max. Lifting Angle	°	75
Max. Outreach	m	12.2
Number of Booms	section	4
Slewing Angle	°	endless
Stabilizer Spread	mm	5200
Fitting Space Required (Std.)	mm	1000
Max. Flow Rate	l/min	45-50
Rated pressure	mpa	25
Hydraulic Oil Tank Capacity	l	140
Crane Weight	kg	2230

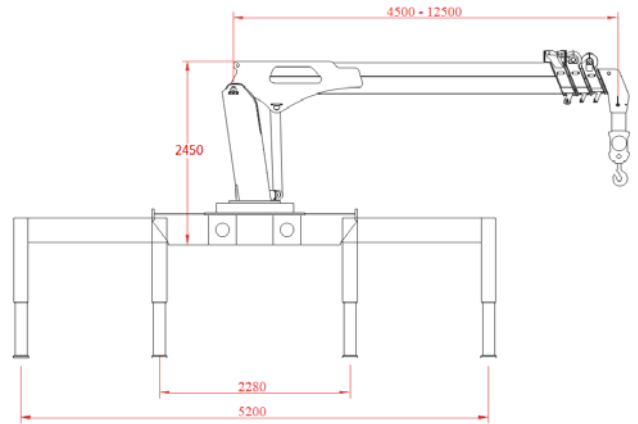

## Lifting Capacities

SPS16000 Rated Lifting Capacity				
Outreach (m)	Full-extend outriggers, over side and rear			
	4.7m	7.3m	9.9m	12.5m
2.5	7000	3470	2210	
3	5200	3310	2140	1810
3.5	4100	3190	2110	1710
4	3500	2900	2100	1650
4.5	3000	2630	2070	1590
5		2340	2000	1500
5.5		2100	1910	1450
6		1940	1800	1390
6.5		1790	1660	1310
7		1650	1580	1250
7.5			1440	1190
8			1370	1120
8.5			1270	1070
9			1190	1000
9.5			1100	930
10				880
10.5				830
11				780
11.5				740
12				690

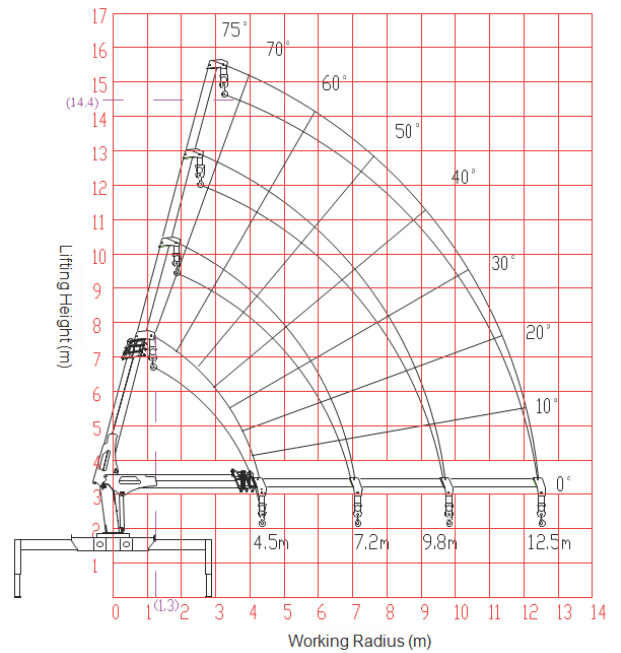

Distributed by

Units shown in the leaflet are partially optional equipped and do not always correspond to the standard version. Country-specific regulations must be observed. Dimensions may vary. Subject to technical changes, errors and translation mistakes.