

SPS 14000

PALFINGER SANY

A COMPACT OPTION FOR 2 AXLE TRUCKS

6.0t
Max Lifting
Capacity

11.5m
Max.
Outreach



SPS14000

B (4 BOOM)

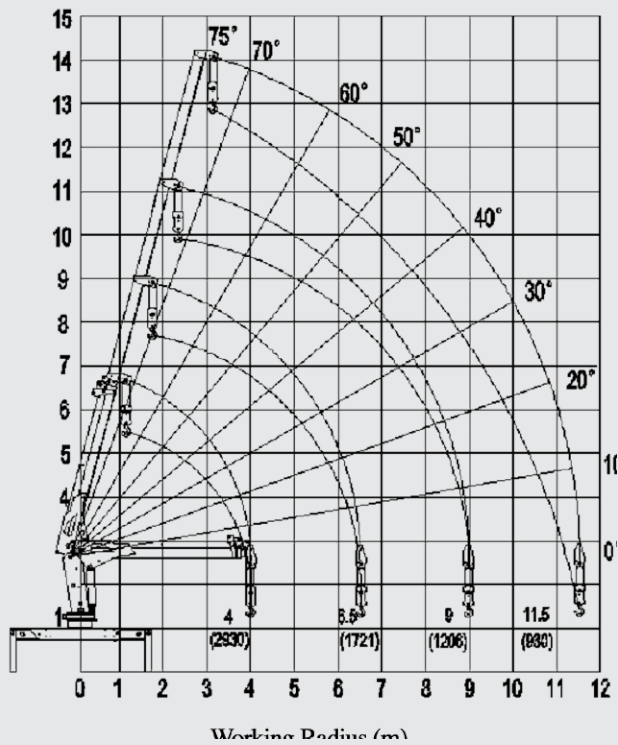

DIMENSIONS

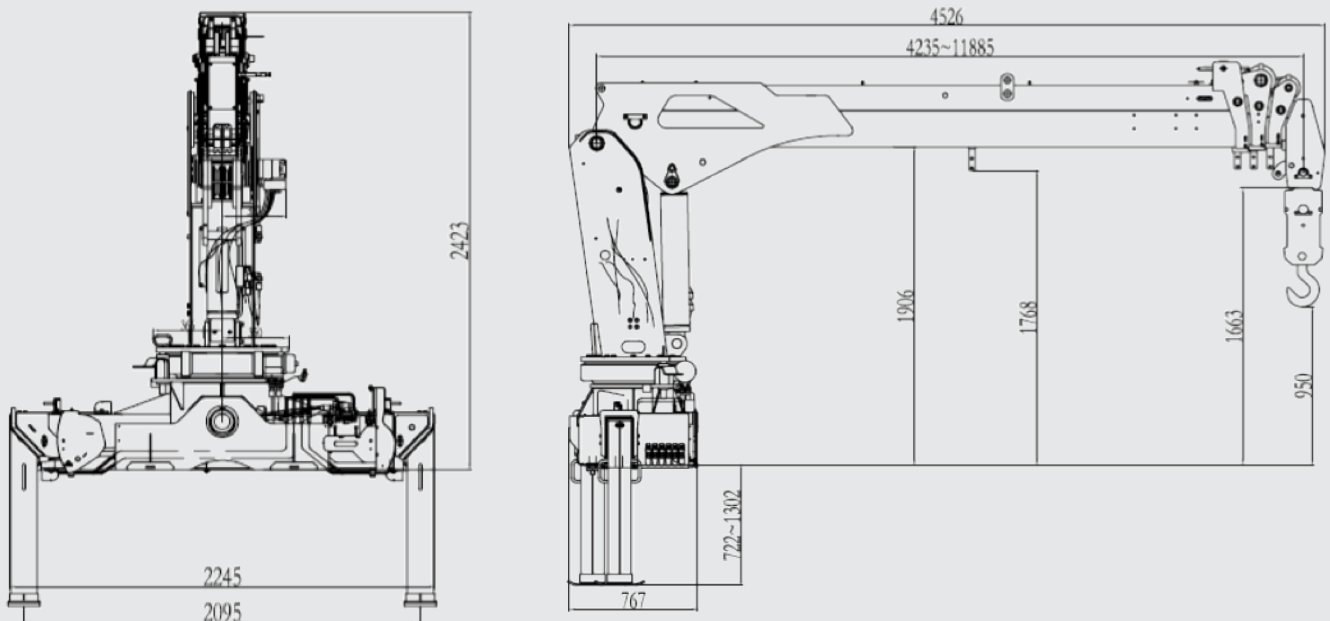



* The diagram above illustrates maximum dimensions

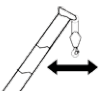

- Longer boom ideal for wide working areas
- Strong lifting performance
- Proportional control valve for smooth controllability and high operating efficiency
- Best lifting performance in its class
- Manufactured with European quality processes to ensure safety and reliability
- Suitable for installation on 2 axle trucks

LIFTING CAPACITY

SPS 14000 (B)				
				
	4.2m	6.8m	9.3m	11.9
2.2	5900	5480		
2.5	5420	4790	4400	
3	4780	4180	3800	
3.5	4250	3740	3380	3200
4	3460	3400	3050	2880
4.5		3100	2790	2600
5		2850	2570	2400
5.5		2640	2390	2200
6		2080	2230	2100
6.5		1900	2100	1950
7			1950	1850
7.5			1850	1750
8			1740	1650
8.5			1600	1550
9			1400	1500
9.5				1400
10				1320
10.5				1250
11				1200
11.5				1100

TECHNICAL SPECIFICATIONS

Model	SPS 14000 B	
Max. lifting moment	mt	14
Max. lifting capacity	kg/m	5900/2.2
Number of booms	sections	4
Max. outreach	m	11.5
Max. lifting angle	°	75
Slewing angle	°	Endless
Stabilizer spread (std.)	mm	5100
Operating pressure	MPa	25
Recommended pump capacity	l/min	55
Oil tank capacity	l	140
Crane Weight	kg	2233



* Optional features / country-specific equipment

SERVICE

WE ARE ALWAYS HERE FOR YOU

PROJECT ENGINEERING

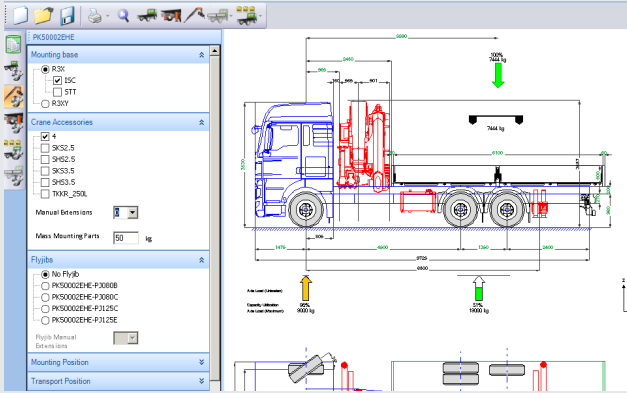

The use of PALSOFT and other selected softwares allows us to address the requests of our clientele from subframe design to stability calculations, and deliver the best vehicle integration solutions.

TECHNICAL SUPPORT



Service is PALFINGER's top priority. Your products are overseen by our highly trained and professional service department either in person or via phone and email.

TRAINING



Here at PALFINGER, we offer a multitude of training programmes (Basic Hydraulic Course, Commissioning, etc.) to cover the needs of all our clientele. Certified trainers will conduct these programmes and training documents can be obtained after completion.

GENUINE SPARE PARTS



Our global distributor network provides an efficient local service for all our customers. Backed by PALFINGER's expert recommendation, we ensure the optimal spare part choices for your cranes.

Authorized Dealer:

Asia Pacific Distribution Managed By:

PALFINGER CRANES INDIA PRIVATE LIMITED

No 37, Varadarajapuram, Nazarethpet, Poonamallee, Chennai - 600 123 | India
www.palfinger-india.com; sales-pci@palfinger.com