

HD 85 PLUS



ESCORTS



OUR REACH

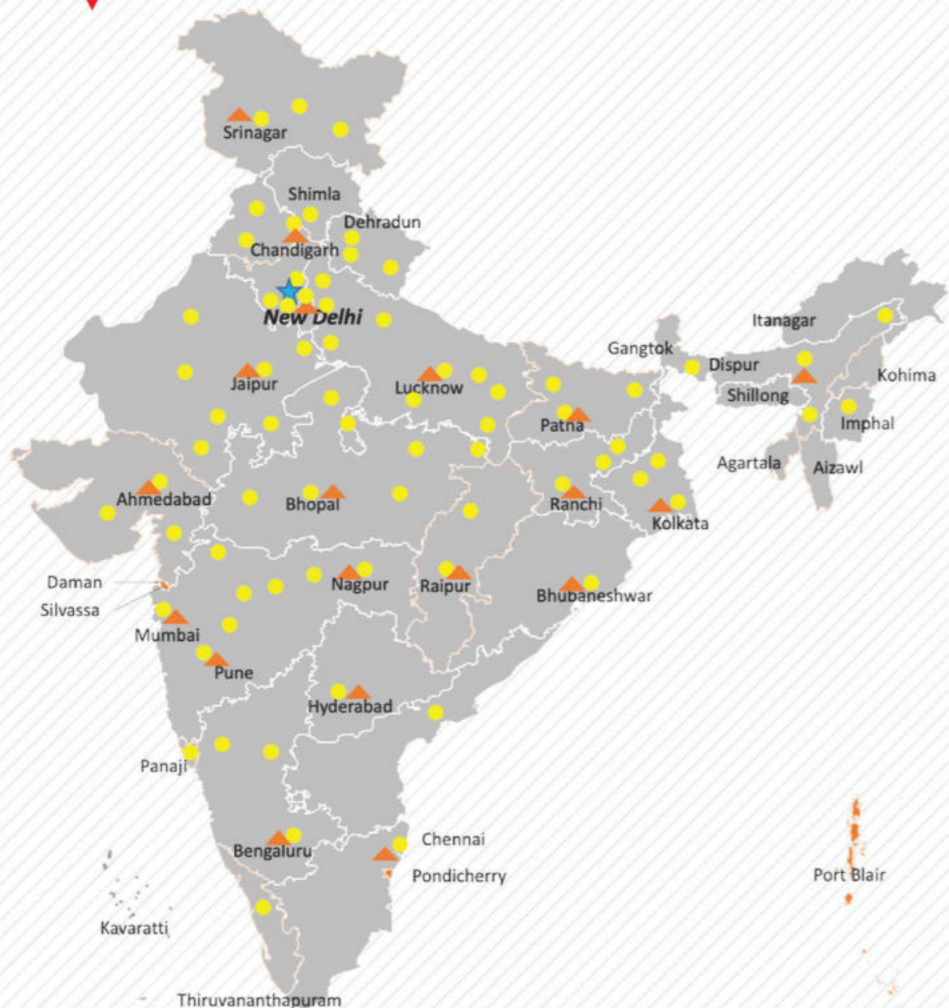

★ Head Office | ▲ 17 Business Center | ● 73 Dealers | ■ 825+ Customer Touch points (CTP)

HD 85 PLUS TAKE THE ROAD AHEAD



(Accessories as shown in the picture may not be the part of standard fitment and are subject to change without prior notice.)

MKT/22/HD 85 PLUS



Toll Free No.:
1800-180-4488
(Timings: 9.30 am - 6.00 pm, Monday to Friday)
e-mail: ece.help@escorts.co.in

Escorts Kubota Limited (Formerly Escorts Limited) Construction Equipment
Plot No. 219, Sector- 58, Ballabhgarh- 121 004, Faridabad, Haryana (INDIA)
Tel.: 0129-2306574/2306598/2306571
Fax: 0129-2306572 Website: www.escortsgroup.com

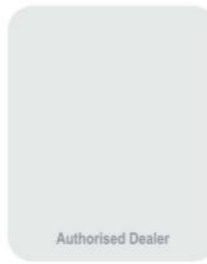

- Operating Weight **9T**
- Fuel **Efficient**
- Compaction Force **High**
- Gradeability **High**
- Maintenance Cost **Low**

•The information contained in this leaflet is intended to be of a general nature only. •We reserve the right to changed specifications without notice. •All Dimensions and weights are variable within +/-5%.

SPECIFICATIONS

HD 85 PLUS

ENGINE		
Make	ESCORTS E4.346CRS4	
Type	4 Cylinder, Water Cooled, CEV STAGE-IV Emission Norms	
Rated Power	75 HP @ 2000 RPM	

STEERING		
Steering Angle	Deg	± 30
Oscillation Angle	Deg	± 10
Turning Radius-outer/inner	mm	6475/4750

WEIGHT		
Operating Weight	kg	9120
Weight on Front Drum	kg	4470
Weight on Rear Drum	kg	4650
Static Linear Load Front/ Rear	kg/cm	26.6/27.7
Centrifugal Force per Drum, Low	kg	6020
Centrifugal Force per Drum, High	kg	6626
Total Applied Load Both Drums, Low	kg	21161
Total Applied Load Both Drums, High	kg	22372

SPEED		
Working	km/hr	0-8.5
Travelling	km/hr	0-13.8

GRADEABILITY		
Gradeability Without Vibration	%	36
Gradeability With Vibration	%	30

VIBRATION SYSTEM		
Frequency	Hz	33/50
High Amplitude	mm	1.0
Low Amplitude	mm	0.4

CAPACITY		
Water Tank	Ltr	800
Fuel Tank	Ltr	160
Hydraulic Oil Tank	Ltr	80

ELECTRICAL SYSTEM		
Battery	12V, 150AH	

BRAKES		
Service Brake	Hydrostatic	
Parking Brake, Emergency Stop	Spring Loaded Brake, Hydraulically released on both drums	

DIMENSIONS		
Length	mm	4175
Width	mm	1780
Height (With Canopy)	mm	3110
Loading Height	mm	2680
Drum Width	mm	1680
Drum Diameter	mm	1200
Shell Thickness	mm	17
Wheel Base	mm	2900
Ground Clearance	mm	290
Kerb Clearance	mm	730

SALIENT FEATURES		
<ul style="list-style-type: none"> • Tilttable Steering • Sliding Operator Seat • Collapsable Roof • Double Water Pump • Fuel Level Gauge • Water Level Gauge 		

SAFETY DEVICES		
<ul style="list-style-type: none"> • Neutral Start Switch • Air Filter Clog Indicator • Hydraulic Filter Clog Indicator • Visual Warning Against Parking Brakes • Auto-Vibration & Sprinkler Cutoff • Starter Safety Relay • Audio Visual Warning For High Coolant • Temperature & Low Lube Oil Pressure • Over & Long Cranking Protection • Vibration Delay Relay • Battery Cut off Switch 		

KEY FEATURES		
<ul style="list-style-type: none"> • Sprinkler Nozzles visible from operator seat • Water Pump, 2 nos. for uninterrupted operation • Foldable canopy frame to decrease height during transportation • High kerb clearance for effective compaction along culverts • Swivel Operator seat including steering wheel, FNR lever and instrument panel for drum edge visibility • High Static Liner Load • Low Turning Radius • Compact Design 		

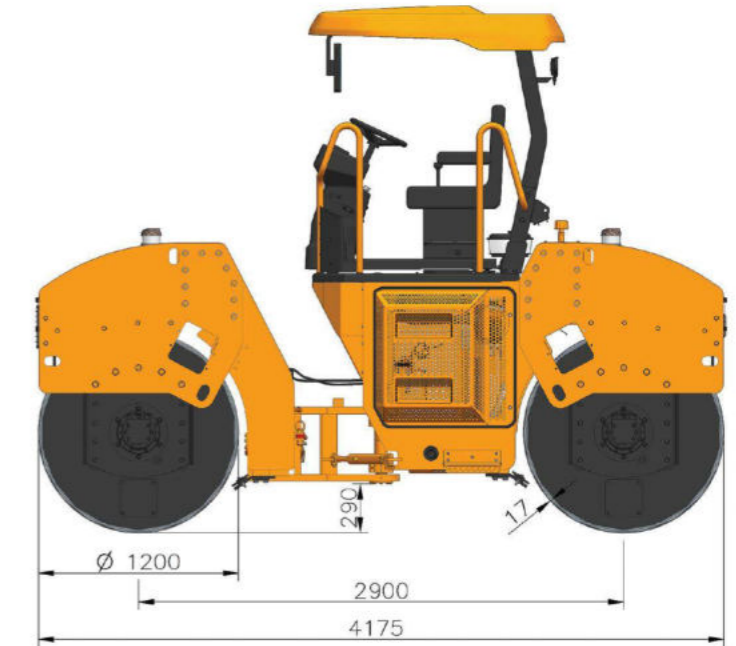
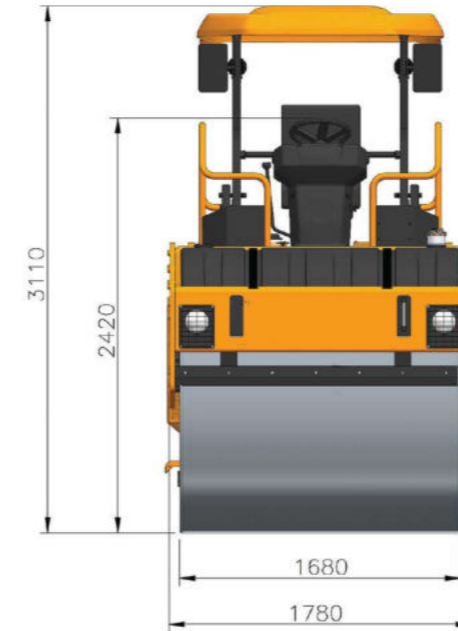

FEATURES



ENGINE

- 75 HP 4 Cylinder CEV STAGE-IV Emission Norms water cooled engine
- Best-in-class fuel economy
- High on performance
- Low maintenance cost



GRADEABILITY AND COMPACTION SYSTEM

- High Gradeability making it versatile for all applications
- Optimised setting Amplitude 1.0/0.4 mm with frequency 33/50 Hz
- Delay relay to avoid the sudden impact while switching from one frequency to another
- High Kerb clearance for better road edge compaction



INSTRUMENT PANEL

- Dust and Weather proof instrument panel
- IP 67 Compliant instrument panel and rocker switch for high reliability



OPERATOR PLATFORM

- Ergonomically designed space for operator comfort
- Foldable 2 post Canopy legs for ease of transportation
- Rotating platform with tilttable steering
- Resilient rubber mounts, low vibration transfer to operator



OPTIMUM VISIBILITY

- 360° visibility
- Clear drum edge visibility from operator seat
- Compact design



SPRINKLING

- Sprinkling nozzles visible from operator seat
- Sprinkling nozzles with three stage filtration to avoid clogging
- Tongue-type nozzles to avoid rusting
- Wide flat fan with a sharp delimited spray pattern for long last uses

HD 85 PLUS



ESCORTS
CONSTRUCTION EQUIPMENT



HD 85 PLUS

TAKE THE
ROAD
AHEAD

