



AQUARIUS ENGINEERS PVT. LTD.

Concrete Pumps, Batching Plants, Boom Pumps



STATIONARY BATCHING PLANTS - SP SERIES



Salient Features:

- ▶ Optimized aggregate loading height
- ▶ Robust structure with corrugated bins
- ▶ Large mixer platform for ease of maintenance
- ▶ Added safety with double wire rope for skip
- ▶ Control cabin included in standard scope
- ▶ Drive through design for increased productivity
- ▶ Special configuration for Ice dosing and Micro silica dosing
- ▶ The Skip Hoist or Belt arrangement option for mixer loading
- ▶ Modular design providing flexibility to adopt to different layout requirements
- ▶ Designed for ready-mix producers, contractors, precast manufacturers and special applications
- ▶ Available with 0.5 cubic meter batch size Planetary Mixer and 1 cubic meter and above Twin Shaft Mixers
- ▶ Available in various capacities ranging from 30 cubic meter to 240 cubic meter per hour of compacted concrete output
- ▶ The Plants are provided with four, five or six in-line Aggregate Bins with an option of total storage capacity from 30 to 250 cubic meter, based on plant size
- ▶ Deliver consistent quality concrete and are most preferred in the RMC industry
- ▶ Specially designed plants for dam projects, hollow core precast and concrete block producers
- ▶ High precision load cells for independent electronic weighing of cement, aggregates & water with digital display
- ▶ Two-level PLC based control system with real-time SCADA for control and data management, AQ - SMART RT - SMART

SP 60 C Precast





SP 90 C

Technical Specifications:

Model Specifications	Unit	SP 30	SP 40	SP 60 SP 60 C	SP 70 SP 70 C	SP 90 C	SP 120 C
Type of Mixer	-	Planetary	Planetary	Twin Shaft	Twin Shaft	Twin Shaft	Twin Shaft
Dry Fill Capacity of Mixer	l	750	900	1500	1800	3000	4500
Compacted Output per Batch	l	500	600	1000	1250	2000	3000
Max. No. of Aggregates	no.	4	4	4/5/6	4/5/6	4/5/6	4/5/6
Storage Capacity of Aggregate	m ³	30	30	40 to 240	40 to 240	70 to 240	70 to 240
Max. No. of Cement / Fly Ash	no.	3	3	4	4	4	4
Max. No. of Water	no.	2	2	2	2	2	2
Max. No. of Additives	no.	2	2	3	4	4	4
Aggregate Loading in Mixer	-	Skip Hoist	Skip Hoist	Skip Hoist/Belt	Skip Hoist/Belt	Conveyor Belt	Conveyor Belt
Connected Load#	kW	52	58	88	90	130	180
D.G. Set Required#	kVA	80	80	150	180	280	320

Standard Configuration

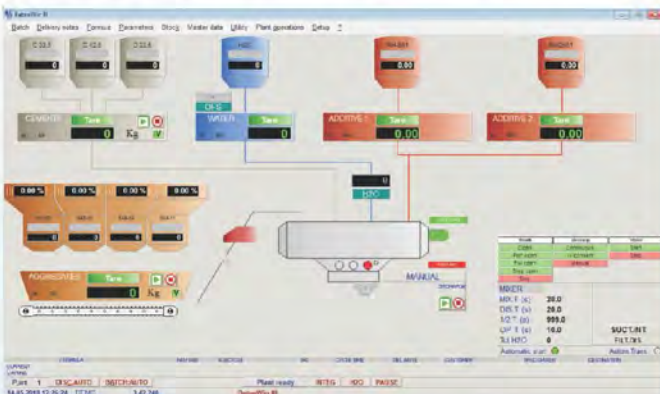

Control System & Software

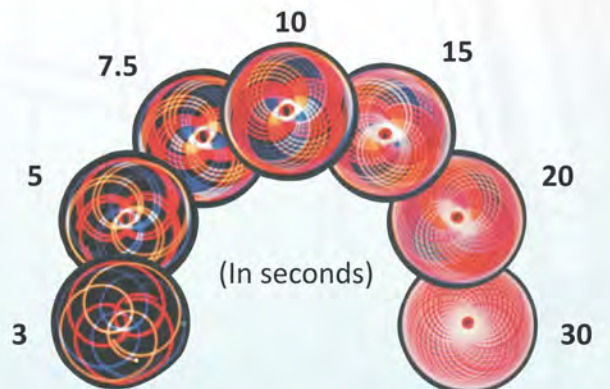

Planetary Mixing Action

Control System:

- ▶ SCADA based control systems, customized to the requirements of various segments
- ▶ Features like auto-in-flight, stock maintenance, on screen diagnosis, production data handling, automatic delivery challan and cycle data printing, etc.
- ▶ The systems are designed based on all feedbacks and requirements from various operation levels
- ▶ Computer provided as a part of standard scope

Twin Shaft Mixer

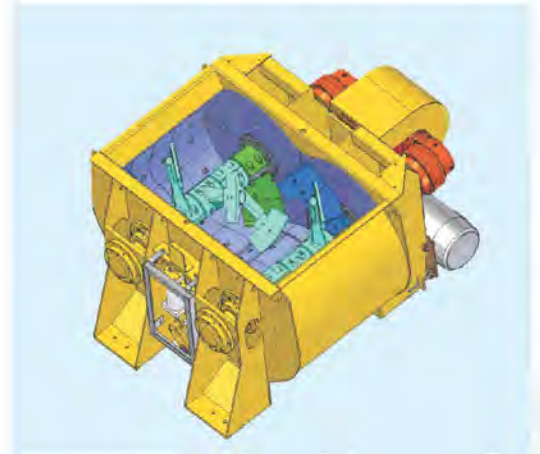

Cycle Time Charts:

STATIONARY BATCHING PLANT - SP 30

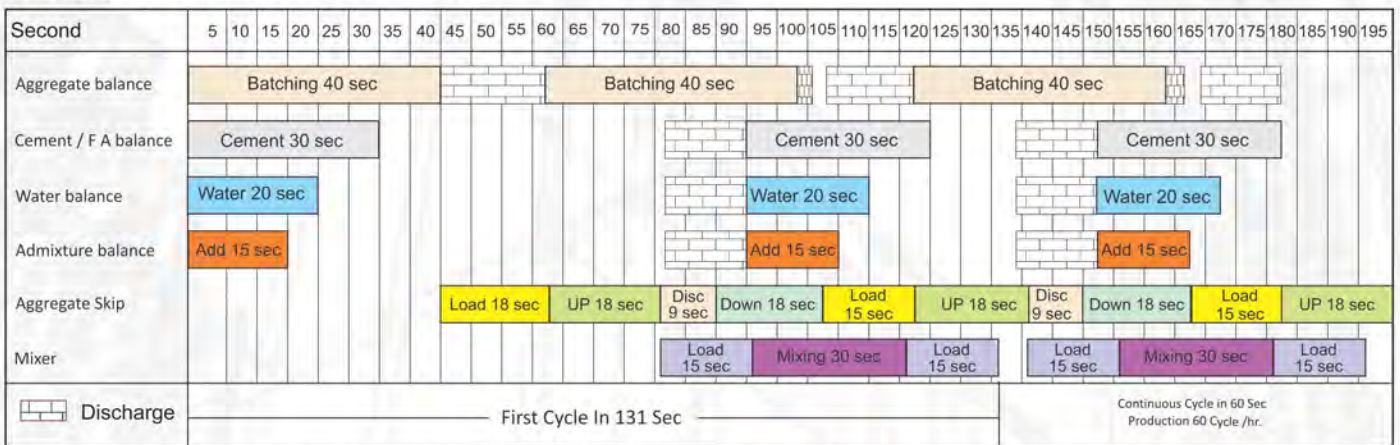

NOTE: Production capacity based on 0.5 m³ cycles of standard concrete with 4 aggregates, 1 cement, 1 water, 1 admixture; slump 7-13 cms.

STATIONARY BATCHING PLANT - SP 60

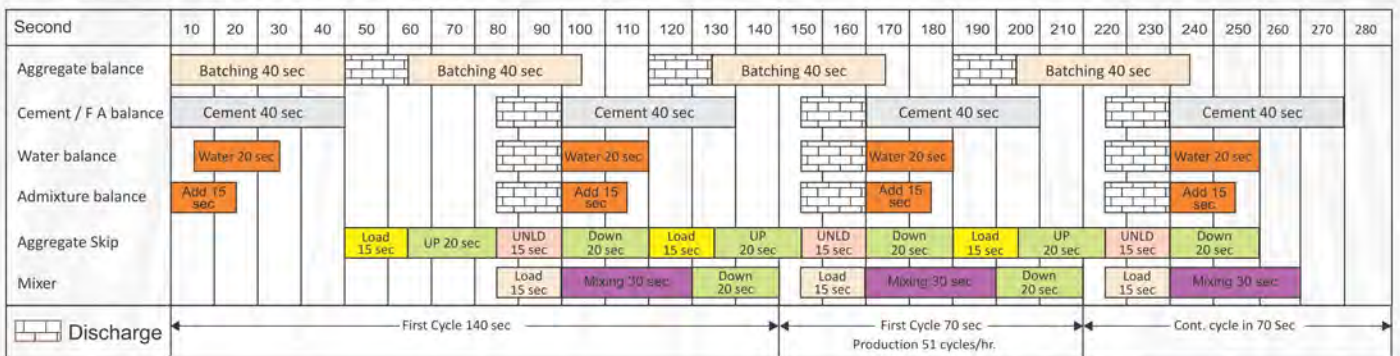

NOTE: Production Capacity based on 1 m³ cycles of standard concrete with 4 aggregates (Max. 2000 kg/m³), 1 Cement (Max. 300 kg/m³), 1 water (Max. 160 kg/m³) & 1 admixture (Max. 4 kg/m³), 30 sec mixing time, 20 sec discharge time normal slump 70 - 130 mm.

Performance of equipment is based on standard working conditions. Design / Specifications can be changed without prior notice.



AQUARIUS ENGINEERS PVT. LTD.

Concrete Pumps, Batching Plants, Boom Pumps
An ISO 9001 : 2015 Certified Company

'Aquarius House', Sheelavihar Colony, Off Karve Road,
Pune 411 038. INDIA Tel.: +91 20 2544 5227 / 28
E-mail: enquiries@aquariusengineers.biz
Web: www.aquariusengineers.biz

Works: S. No. 480,481 & 482, Ambadwet, Tal. Mulshi, Dist.
Pune - 412 111

Local Contact: